

BUCK-BOOST MODE SWITCHING METHOD FOR A DC-DC CONVERTER, AND DC-DC CONVERTER

Main Technological Area —> Electric Networks

Keyword —> DC | bus | High Voltage | Low Voltage | Threshold.

Bi-directional DC-DC converter designed to operate between a high voltage bus and a low voltage bus, automatically adapting the operation to restore / maintain the required voltage levels.

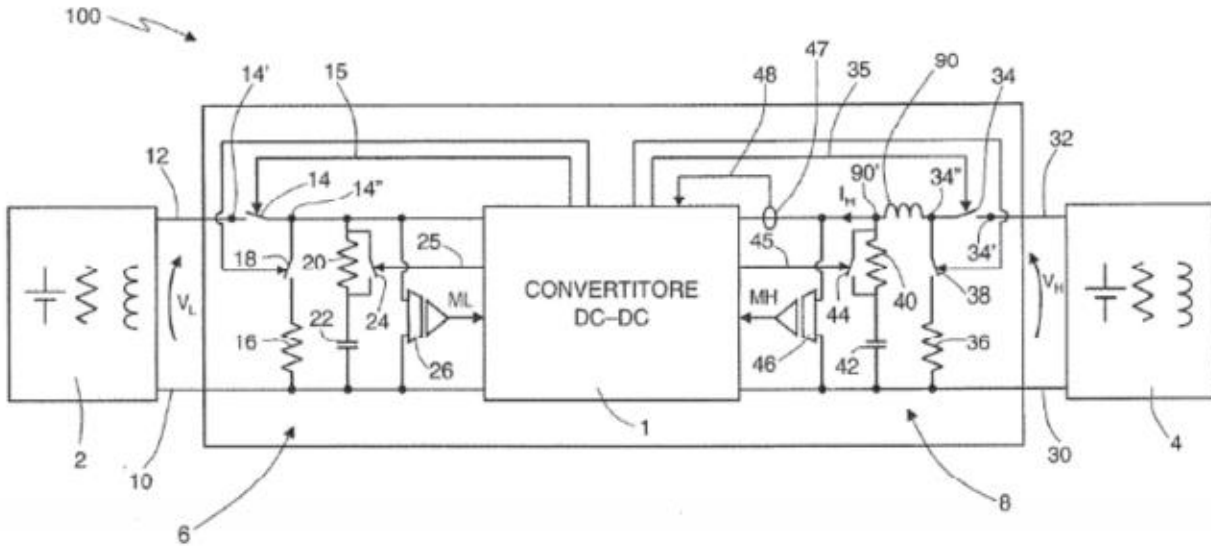

Figure 1

TECHNICAL FEATURES

A bi-directional DC-DC converter basically performs two operations:

- "boost Mode ": stepping up the voltage between an input bus, where there is a low-voltage DC source (28 V for example), and an output bus, where a higher DC voltage than that present on the input side is required (270 V for example);
- "buck mode" stepping down the voltage between an input bus, where there is a high-voltage DC source, and a output bus, where a lower DC voltage than that present on the input side is required.

The converter automatically sets itself in "boost mode" when the voltage on the "high voltage bus" is lower than the specified threshold.

The converter automatically sets itself in "buck mode" when the voltage on the "low voltage bus" is lower than the specified threshold.

INNOVATION/BENEFITS

In the state of the art, the transition from "buck mode" to "boost mode" and vice versa is not automatic, or automatic but not "transparent" i.e. through an electronic control external to the converter that manages the transition. The solution proposed here achieves the transition from "buck mode" to "boost mode" in "automatic" and "transparent" mode, i.e. through the intrinsic characteristics of the "bi-directional DC-DC converter" illustrated in the circuit diagram in Figure 2.

AREAS OF USE

Electricity distribution networks

PATENT INFORMATION

Priority Date – 2010/06/03

Priority Number IT TO2010A000465

IPC Codes– H02M 3/335, H02M 1/32

Active Worldwide Extensions

EPO – EP2393196B1; Filing Date 2011/06/03; Grant Date 2014/04/11/
Italy - Germany – France – United Kingdom – Spain-Sweden

Leonardo internal code

LDO- -A468

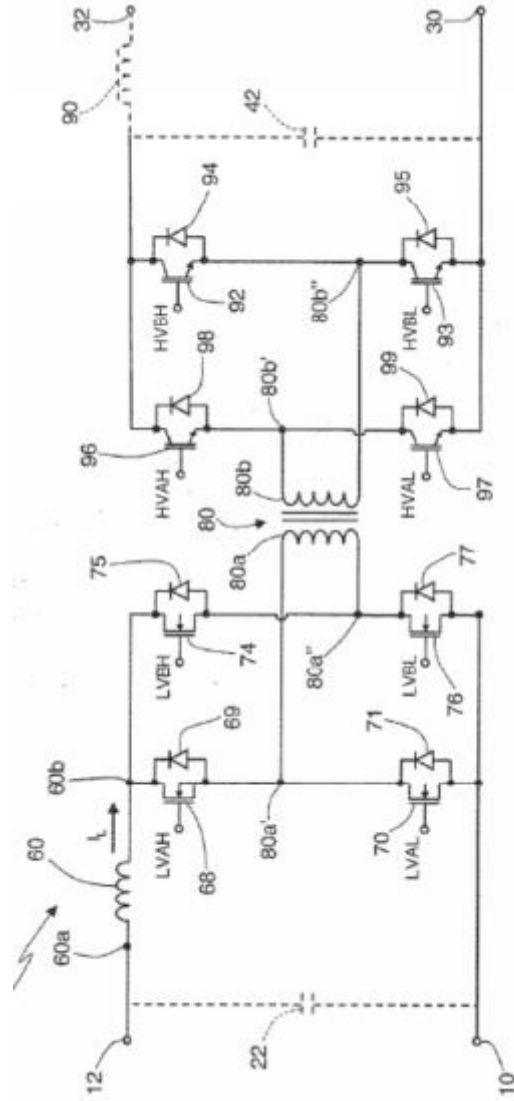

Figure 2